



Holger Kappeler

Superflex Heavy MPP 17K



RICKMERS-LINIE

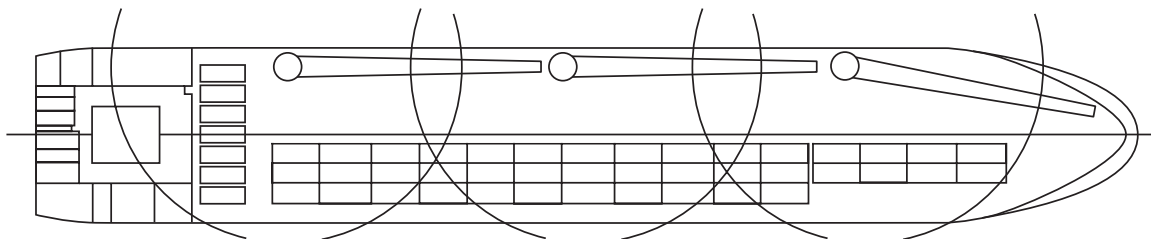
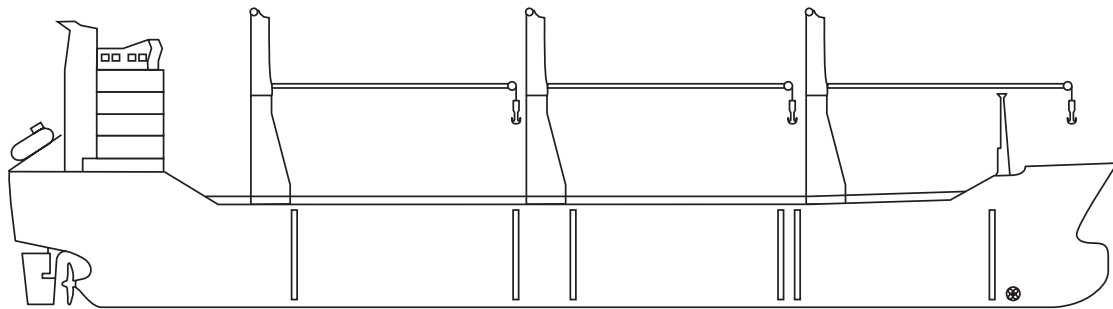

Technical Details

(all details about)

Tonnage	GT	NT	Length o.a.	144,00 m
	ca. 12.400		Length p.p.	134,00 m
Deadweight	dwt		Breadth	22,80 m
	17.000		Draught scantl.	9,85 m

Machinery

Machinery	1 x 7-Cyl. Diesel
Power	8.730 kW
Max. Speed	16,0 kn

Capacities

Gear	2 cranes each	150 t	Cargo Cap. (grain)	ca. cbm 19.000
	combined	300 t		Container Cap.
	1 crane aft	80 t		

Holds and Hatches

Hold 1	20,50 x 13,21 m	Hold 2	38,80 x 18,60 m	Hold 3	26,20 x 18,60 m
---------------	-----------------	---------------	-----------------	---------------	-----------------

> lifting capacity of up to 300 tons

> Box shaped



RICKMERS-LINIE

www.rickmers-linie.com